

BO8724N2B | 外转子无传感器 Outer Rotor, Sensorless

应用领域：无人机、电动自行车、工业设备等精密驱动领域。

Applications: UAV, E-bike, industrial automation, etc.

主要技术指标 | Characteristics

			01-36-48.0	02-36-36.0	03-36-24.0	
1	电压	Voltage	V	48.0	36.0	24.0
2	端电阻	Terminal resistance	Ω	0.33	0.17	0.085
3	空载转速	No-load speed	rpm	3600	3600	3600
4	空载电流	No-load current	A	0.5	0.7	1.0
5	堵转转矩	Stall torque	mNm	18393	20089	17848
6	堵转电流	Stall current	A	145.5	211.8	282.3
7	额定转矩	Nominal torque	mNm	1210	1210	1210
8	额定转速	Nominal speed	rpm	3200	3200	3200
9	额定电流	Nominal current	A	9.7	13	19.5
10	最大输出功率	Max. output power	W	1732	1892	1681
11	最大效率	Max. efficiency	%	88.6	88.8	88.4
12	反电势常数	Back-EMF constant	mV/rpm	13.3	10.0	6.6
13	转矩常数	Torque constant	mNm/A	126.9	95.2	64.3
14	KV 值	KV Value	rpm/V	75	100	133.3
15	转速 / 转矩斜率	Speed/torque gradient	rpm/mNm	0.2	0.2	0.2
16	转子惯量	Rotor inertia	gcm ²	510	510	510
17	重量	Weight	g	270	270	270
18	热阻 (机壳 - 环境)	Thermal resistance housing-ambient	K/W		1.1	
19	热阻 (线圈 - 机壳)	Thermal resistance winding-housing	K/W		0.48	
20	热时常数 (电机)	Thermal time constant motor	s		340	
21	热时常数 (线圈)	Thermal time constant winding	s		50	
22	工作温度范围	Operating temperature range	°C		-40~+120	
23	绕组耐温等级	Thermal class of winding	°C		180	
24	轴向间隙	Axial play	mm		0.012	
25	径向间隙	Radial play	mm		0.008	
26	动态轴向载荷	Axial load dynamic	N		10	
27	静态轴向载荷	Axial load static	N		140	
28	径向载荷 (距安装面 3mm)	Radial load at 3 mm from mounting face	N		145	
29	极对数	No. of pole pairs			21	
30	轴承	Bearings			2 枚滚动轴承/2 ball bearings	
31	换向结构	Commutation			无传感器/Sensorless	
32	防护等级	Protection class			IP 20	

★可选参数 Options: 导线长度 Lead wires length 轴长 Shaft length 性能 Special coils

轴承类型 Bearing type 驱动器 Driver

外观图 | Outline Drawing

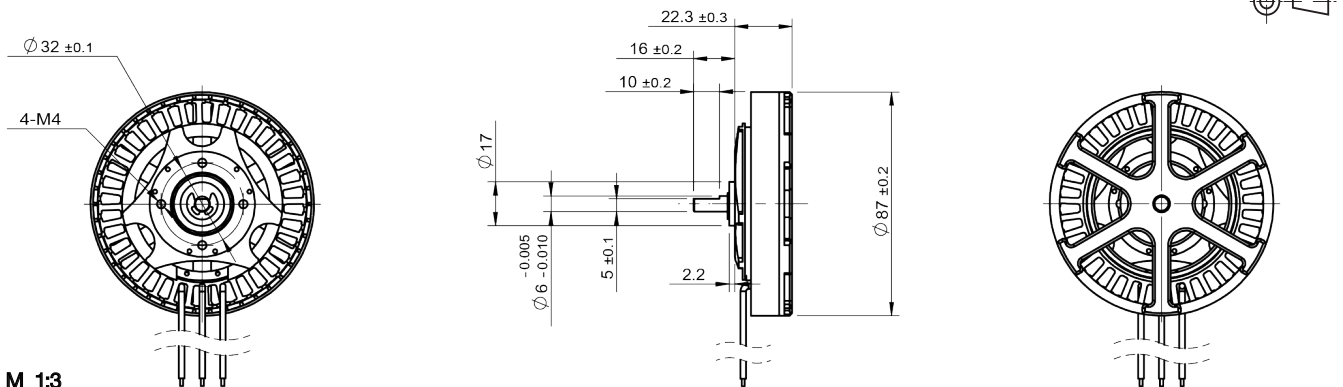

M 1:3