

1625N5C | 碳刷 Graphite Brush

应用领域：医疗、保健、汽车、机器人、工业自动化等精密驱动领域。

Applications: precision drives in medical equipment and devices, healthcare products, automotive, robotics, and industrial automation.

主要技术指标 | Characteristics

				01-150-12.0
1	电压	Voltage	V	12.0
2	转子电阻	Rotor Resistance	Ω	13.0
3	空载转速	No-load speed	rpm	15000
4	空载电流	No-load current	mA	25
5	堵转转矩	Stall torque	mNm	6.7
6	堵转电流	Stall current	mA	920
7	额定转矩	Nominal torque	mNm	3.3
8	额定转速	Nominal speed	rpm	7560
9	额定电流	Nominal current	mA	470
10	最大输出功率	Max. output power	W	2.6
11	最大效率	Max. efficiency	%	70
12	反电势常数	Back-EMF constant	mV/rpm	0.8
13	转矩常数	Torque constant	mNm/A	7.4
14	转速 / 转矩斜率	Speed/torque gradient	rpm/mNm	2250
15	转子惯量	Rotor inertia	gcm ²	0.95
16	重量	Weight	g	22.5
17	热阻 (机壳 - 环境)	Thermal resistance housing-ambient	K/W	25.04
18	热阻 (线圈 - 机壳)	Thermal resistance winding-housing	K/W	9.71
19	热时常数 (电机)	Thermal time constant motor	s	190
20	热时常数 (线圈)	Thermal time constant winding	s	147
21	工作温度范围	Operating temperature range	°C	-20~+85
22	绕组耐温等级	Thermal class of winding	°C	130
23	轴向间隙	Axial play	mm	0.02~0.15
24	径向间隙	Radial play	mm	0.012
25	动态轴向载荷	Axial load dynamic	N	0.8
26	静态轴向载荷	Axial load static	N	30
27	径向载荷 (距安装面 3mm)	Radial load at 3 mm from mounting face	N	1.5
28	极对数	No. of pole pairs		1
29	轴承	Bearings		2 枚含油轴承/2 sleeve bearings
30	换向结构	Commutator		贵金属 5 相/metal 5 segments
31	防护等级	Protection class		IP 30

★可选参数 Options: 导线长度 Lead wires length 轴长 Shaft length 性能 Special coils 轴承类型 Bearing type

齿轮箱 Gearheads 编码器 Encoder

外观图 | Outline Drawing

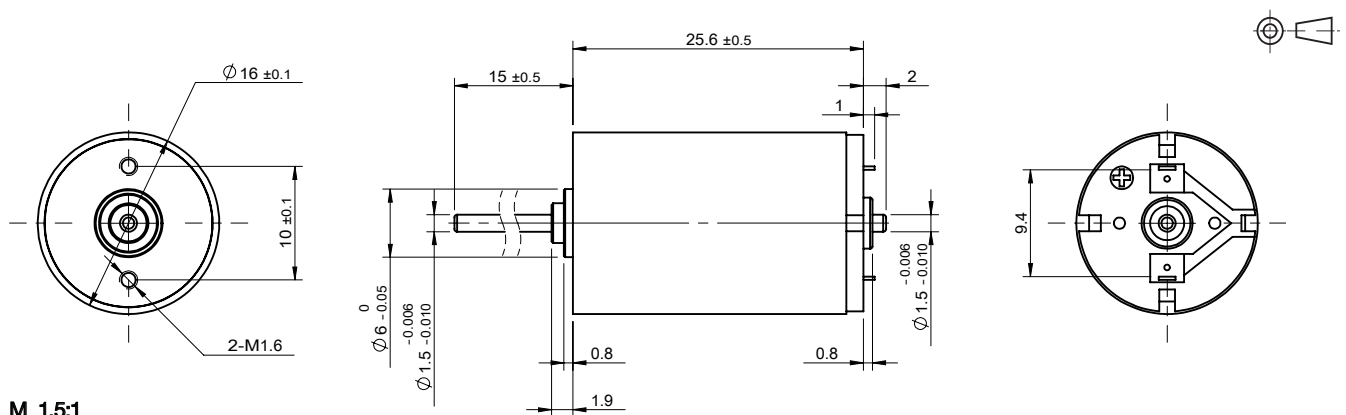

M 1.5:1