

BO1815N2B | 外转子无传感器 Outer Rotor, Sensorless

应用领域：无人机、航模等驱动领域。

Applications: UAV, aeromodelling, etc.

主要技术指标 | Characteristics

			01-199-6.0	02-199-9.0	03-199-12.0	
1	电压	Voltage	V	6.0	9.0	12.0
2	端电阻	Terminal resistance	Ω	0.21	0.43	0.72
3	空载转速	No-load speed	rpm	19900	19900	19900
4	空载电流	No-load current	A	0.32	0.21	0.14
5	堵转转矩	Stall torque	mNm	81	89	94
6	堵转电流	Stall current	A	28.9	21.1	16.7
7	额定转矩	Nominal torque	mNm	18.0	17.1	18.5
8	额定转速	Nominal speed	rpm	9550	11100	11070
9	额定电流	Nominal current	A	6.1	4.6	3.7
10	最大输出功率	Max. output power	W	42	47	49
11	最大效率	Max. efficiency	%	80.0	81.1	82.6
12	反电势常数	Back-EMF constant	mV/rpm	0.3	0.4	0.6
13	转矩常数	Torque constant	mNm/A	2.9	4.3	5.7
14	KV 值	KV Value	rpm/V	3307	2212	1664
15	转速 / 转矩斜率	Speed/torque gradient	rpm/mNm	243.5	223.2	212.0
16	转子惯量	Rotor inertia	gcm ²	2.8	2.8	2.8
17	重量	Weight	g	11	11	11
18	热阻 (机壳 - 环境)	Thermal resistance housing-ambient	K/W		2.8	
19	热阻 (线圈 - 机壳)	Thermal resistance winding-housing	K/W		2.4	
20	热时常数 (电机)	Thermal time constant motor	s		173	
21	热时常数 (线圈)	Thermal time constant winding	s		112	
22	工作温度范围	Operating temperature range	°C		-40~+120	
23	绕组耐温等级	Thermal class of winding	°C		180	
24	轴向间隙	Axial play	mm		0.012	
25	径向间隙	Radial play	mm		0.008	
26	动态轴向载荷	Axial load dynamic	N		1.5	
27	静态轴向载荷	Axial load static	N		37	
28	径向载荷 (距安装面 3mm)	Radial load at 3 mm from mounting face	N		12	
29	极对数	No. of pole pairs			6	
30	轴承	Bearings			2 枚滚动轴承/2 ball bearings	
31	换向结构	Commutation			无传感器/Sensorless	
32	防护等级	Protection class			IP 20	

★可选参数 Options: 导线长度 Lead wires length 轴长 Shaft length 性能 Special coils 齿轮箱 Gearheads 轴承类型 Bearing type

编码器 Encoder 驱动器 Driver

外观图 | Outline Drawing

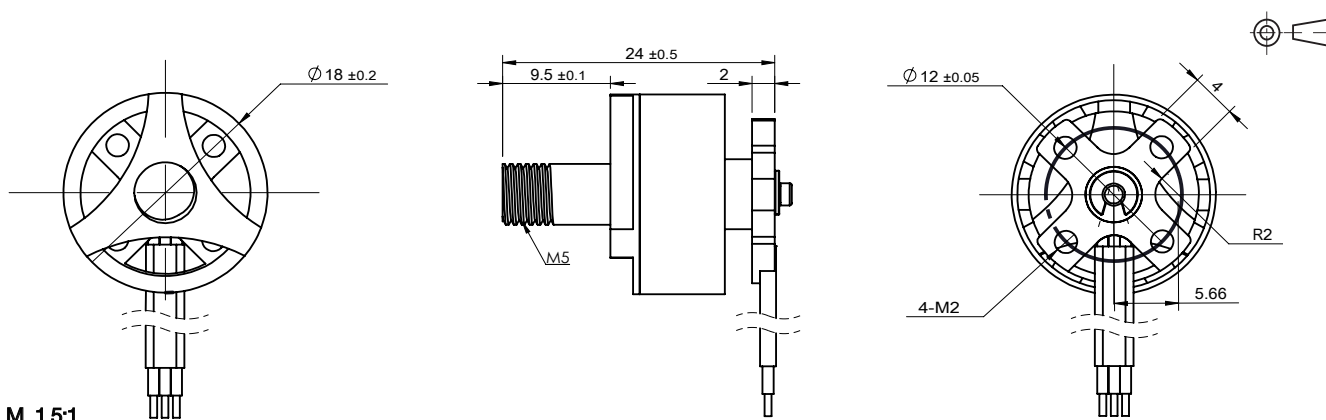

M 1.5:1